

Honeywell

THE POWER OF **CONNECTED**

UNMANNED AIRCRAFT SYSTEM CAPABILITIES

Technology Solutions for Remotely Piloted Vehicles



A Solution for Every Unmanned Mission

Honeywell is applying our unique expertise to meet the specific needs of unmanned aircraft system (UAS) manufacturers. We're a global leader in developing products, services and software solutions for aerospace and have more than three decades of experience in the UAS business with presence on many of the leading platforms flying today.

From powerful propulsion systems and auxiliary power units to sophisticated navigation and electric power systems, we have proven products in the field helping operators of large UAS platforms meet their most demanding military and commercial missions.

But our involvement doesn't stop there. We're already working with our Original Equipment Manufacturer (OEM) partners, government agencies and airspace authorities to develop next-generation products, services and capabilities for both large (Class 4-5) and small (Class 1-3) UAS platforms.

Propulsion Systems

Honeywell and our legacy companies have been on the forefront of turbine propulsion engine technology for nearly 65 years. Our engines power leading military and commercial helicopters, business aircraft and UAS platforms, including the MQ-9 Reaper.

The MQ-9 has flown more than 1 million hours powered by Honeywell's TPE331 turboprop engine. With 1,000 shaft horsepower (900 shp during takeoff) the TPE331 gives the Reaper the power it needs to take on the most challenging hunter and intelligence, surveillance and reconnaissance missions. The TPE331 is a powerful, reliable and economical engine.

Electromechanical Actuators

Leading UAS platforms use Honeywell flight control and utility actuators to control the flaps and other primary flight surfaces on the aircraft. Among other features, our actuators include self-diagnostics and health monitoring to enhance reliability, safety and maintenance.

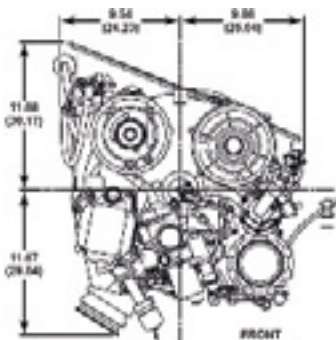

Navigation Systems

Our inertial navigation technology currently equips leading Class 4-5 platforms including the MQ-9 Reaper, Predator, X-47B and K-MAX. We're a leader in EGI (embedded global positioning system/inertial navigation system) technology, which provides UAS platforms with unparalleled levels of performance, accuracy and reliability.

The Honeywell EGI family includes the H-764 and FALCN. These products meet all current civil requirements for operation in controlled air space. Ideal for UAS applications, the FALCN EGI provides all the capabilities of the H-764 in a package that is much smaller and lighter and uses less power. The FALCN weighs 33 percent less than the H-764.

Ground Control Stations

Honeywell has extensive experience in ground control stations, gained during our own UAS development program on the RQ-16 T-Hawk. Our ground station enables pre-programmed missions along with direct manual control and can accommodate flight plans with as many as 100 waypoints.

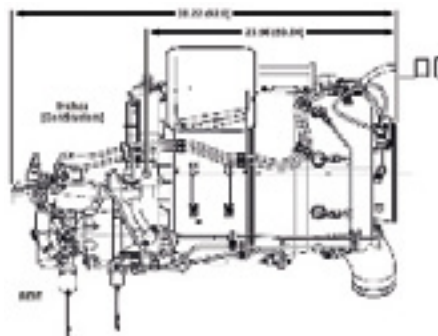

Our areas of expertise include:

- Propulsion Systems
- Navigation Systems
- Auxiliary Power Units
- Electromechanical Actuators
- Ground Control Stations
- High Integrity Controls
- Air & Thermal Systems
- Pneumatics
- Fuel Controls
- Surveillance Systems
- Mechanical Components
- Electric Power Systems
- Isolation and Damping Technologies

Electrical Power

Electric power generation and distribution is a Honeywell specialty. With innovative starter generator and power converter products, we provide UAS platforms with the right solution for their electrical power needs. Our products have evolved along with our customers' needs and the latest generation of electrical power equipment for the Reaper is smaller, lighter, generates more power and is 10 times more reliable than the previous version.

Auxiliary Power Units

A UAS auxiliary power unit provides electrical and/or pneumatic power to the platform in addition to providing emergency power for back-up system capabilities. Our G250 APU, which currently flies on the X-47B, uses technology designed for the fifth-generation fighter environment and can restore power to the system within five seconds if an emergency occurs. The system can operate at altitudes of up to 50,000 feet. Honeywell offers a wide range of other auxiliary power units ranging from 100 up to 1,700 shaft horsepower. These enable a wide range of secondary power solutions based on the size and requirements of the UAS.

Advancing the Science of Unmanned Vehicles

At Honeywell we continue to apply our unique expertise in core technologies that will advance the safety, efficiency and mission-effectiveness of unmanned flight. Current development efforts range from autonomous navigation solutions, to low-cost surveillance and avionics technologies, to hybrid propulsion systems.

Sense and Avoid System

Operating safely and effectively in the commercial airspace is a challenge for the UAV industry – and the entire aerospace community.

With an effective sense and avoid (SAA) system on board, UAS platforms will be able to detect friendly and unfriendly traffic soon enough to maintain safe separation and avoid midair collisions. We're testing the UAS industry's most advanced technology on the MQ-9 Reaper, following extensive prototype testing on our own flying testbed. We also are partnering with various aviation authorities to develop international SAA certification standards.

With our extensive background in situational awareness and collision avoidance technologies, Honeywell is in a unique position to advance the development of this critical UAS capability.



Advanced Inertial Measurement Unit

Our next-generation navigation systems will include the latest inertial measurement units to combine accurate navigation and high reliability with an extended mission life. These new IMUs will be ideal for use in Class 1-3 UAS platforms because they provide the flexibility that manufacturers and operators need in a smaller, more efficient package.

Secure Remote Connectivity

We are working on innovative approaches to ensuring secure communications between UAS platforms and ground operations. With a focus on both satellite communications and other remote communications technologies, we're working to bring together multi-level security standards used in commercial aviation with military protective technologies to enable the best of both worlds.



Hybrid Propulsion

Hybrid electric aircraft appears to be the wave of the future for UAS platforms. We have been selected by the U.S. Defense Advanced Research Project Agency (DARPA) to explore ways to provide future UAS platforms with hybrid propulsion technologies that will enable extended missions.

UAS Traffic Management

As a premier provider of connected-aircraft technologies, Honeywell is determined to bring existing commercial aviation technologies and practices into the UAS world. Examples include the areas of security services, flight services and information services. Honeywell already has an extensive portfolio of commercial aviation services and applications in our GoDirect offering, which shows great potential for the UAS industry.



Aircraft Damping and Isolation

Honeywell's D-strut solutions can save aircraft hundreds of pounds of weight by efficient isolation vibration-induced structural displacements. Optional considerations include munitions isolation, engine-to-aircraft isolation and damping. This technology replaces traditional ineffective visco-elastic damping solutions, however the approach is high Technology Readiness Level (TRL) based on three decades of mission success on multitude of platforms.



If You're Flying Without a Pilot, Fly With Honeywell

Our experience with UAS platforms dates back to the late 1970s when we helped convert vintage fighter aircraft to unmanned aerial targets for the U.S. Air Force. Since then our expertise and the breadth of our UAS technology portfolio has grown dramatically.

We continue to invest in finding new and better ways to help UAS developers, manufacturers and operators meet the challenges they face in this dynamic and growing industry.

Honeywell Aerospace

1944 East Sky Harbor Circle

Phoenix, AZ 85034

International: 1.602.365.3099

U.S. Toll Free: 1.800.601.3099

aerospace.honeywell.com

N61-1760-000-000 | 05/2017
© 2017 Honeywell International Inc.

Honeywell