

700 Series Thermal Switch

High Reliability

Qualified to NASA-Goddard Specifications:

[S-311-641](#), "Switches, Thermostatic, General Requirements" and

[S-311-641/03](#) "Switch, Thermostatic, Corrosion Resistant Steel, Hermetic"

[S-311-641/04](#): "Switch, Thermostatic, Bimetallic, SPST, High Power, Hermetic, Detail Specification"



Honeywell's 700 Series High-Reliability Thermal Switch is the result of years of meticulous engineering and a relentless path of continuous improvement.

Discriminating designers have specified them from the earliest unmanned satellites to today's most modern manned and unmanned space vehicles.

The product line continues to evolve with the addition of many new standard configurations. The breadth of offerings allows users to select any number of off-the-shelf designs. This saves engineering resources by eliminating the need for customer specifications and non-recurring engineering. Recent design improvements have led to even greater reliability and temperature stability.

These high-reliability switches receive an extensive battery of screening tests, thus assuring customers a product with the highest degree of workmanship and reliability. They meet or exceed the requirements set forth in MIL-PRF-24236/1, Type I, Class 4. Residual gas analysis and Group B testing are performed on every production lot. Upon testing and inspection Honeywell serializes each switch and completes an individual data sheet containing the acceptance test data.

No matter what your high-reliability application may be, Honeywell has the right solution for your system.

Application Examples

- Propulsion Lines
- Electronics compartment temperature control
- Cold plate temperature monitoring and control
- Optics and instrumentation temperature control
- Surface and strip heater control
- Battery charge rate and heater control
- Rocket motors and thrusters
- Overheat protection
- Electric motor pre-heater control
- Hydraulic/pneumatic actuator freeze protection systems
- Environmental control system limit indication and control
- System Fail Safe

Features

- All welded stainless steel construction
- 1000 cycles of run-in while monitoring contact resistance, 50 milliohms max, missed cycle detection
- Residual Gas Analysis and Group B Testing
- Able to withstand high vibration and shock levels
- Push to Open snap-action contact operation
- Meets or exceeds requirements of S-311-641/03
- Stainless and super Alloy Construction
- Internal cleanliness 100% verified by micro-particle analysis
- Each switch serialized and shipped with individual test data sheet
- Low contact resistance: 25 milliohms maximum
- Hermetically sealed & backfilled with dry Nitrogen & 10% Helium tracer

Specifications for 700 Series Thermal Switch

Performance Characteristics	
Contact Arrangement	SPST
Contact Ratings	5 amperes resistive load at 28 VDC for 100,000 cycles
	2 amperes resistive load at 115 VAC RMS for 2,000,000 cycles
	1.0 ampere inductive load (0.02) at 28 VDC, 115 VAC RMS for 100,000 cycles
	1.0 ampere resistive load at 28 VDC 1,000,000
	1.0 ampere resistive at 120 VDC for 250,000 cycles
Dielectric Withstanding Voltage	1250 VAC RMS - terminals to case, 500 microamperes maximum leakage
Insulation Resistance	500 megohms minimum at 500 VDC - terminals to case

Environmental (MIL-STD-202)

Vibration (Sine)	Method 204, 50g to 2000 Hz, 30g to 2500 Hz
Vibration (Random)	Method 214, over 30g RMS, 20 to 2000 Hz
Ambient Temperature Range	-183°F to 400°F (-201° to +204°C)
Moisture Resistance	Method 106, 240 hours, 90-98% RH, and from +77°F to +149°F (+25°C to 65°C)
Hermetic Seal	Method 112, Cond. C, Procedure IV, 1.0 x 10 ⁻⁸ Atm, cc/sec max leak rate
Solderability	Method 208
Shock	Method 213, 100g/6ms, 750g/0.5ms
Thermal Shock	Method 107, Condition B, -120°F to +257°F (-49°C to 125°C)
Acceleration	Method 212, Condition A, 30g
Salt Spray	Method 101, Condition B, 48 hours

NOTE: The 700 Series thermal switches have been qualified to the requirements of Military Specification MIL-PRF-24236, titled "Switches, Thermostatic, General Specification For," for Type I, Class 4 devices.

Acceptance Test Data

Test	Criteria
Contact resistance monitored burn-in	1,000 cycles min, 50 mΩ max`
Random vibration	22.7g RMS
Particle impact noise detection (PIND)	No particle noise
Calibration /setpoint)	3 cycles, 1°F min/max
Creepage (ARC duration) 3 cycles	<5 msec, 600 VDC, 1°F min/max
Seal: fine leak gross leak	≤1 x 10 ⁻⁸ Atm. cc/sec, No bubbles
Contact resistance - 3 cycles	25 milliohms max (6 VDC, .1A)
Weight	Varies by configuration
Dielectric withstanding voltage - Terminals to case	1250 VAC RMS, 60 Hz
Insulation Resistance - Terminals to case	500 megohms min, 500 VDC
Inspection of product	Final visual

Sample Ordering Code

Once written, your ordering code becomes the specific part number, as the following example illustrates: (NOTE: The part number marked on the switches will have the NASA-Goddard prefix G311P641/03.)

	UNIT #						
	1	2	3	4	5	6	7
Configuration shown in drawing	702	S	040	A	060	A	IC
Space rated							
Lower temperature setpoint at 40°F							
A = Open on temperature rise B = Close on temperature rise							
Upper temperature setpoint at 60°F							
Special Feature (see following "Special Feature List")							
Special Physical Feature (Unit 7, see "Configuration Drawings") .375 Stud Length							

- Standard temperature tolerance is ±5°F on opening and closing temperature. Unless otherwise specified, minimum differential is 8°F.

EXAMPLE OF SPECIAL FEATURES. CONSULT FACTORY FOR SPECIFIC APPLICATION Unit #7, Physical Features Available

ORDERING CODE (UNIT 7A)	LEAD WIRE MIL-SPEC
A	M22759/43-22-9
B	M22759/43-20-9
ORDERING CODE (UNIT 7B)	TUBING ADAPTER MOUNTING ANGLE (±10°)
1	0° (Lead Wires Parallel to Tube Direction)
2	45
3	90° (Lead Wires Perpendicular to Tube Direction)
4	135
ORDERING CODE (UNIT 7C)	OTHER OPTIONS
Z	LESS STRAP AND SHIPPING TUBE
Y	LESS STRAP AND SHIPPING TUBE. WITH WIRE TIE FEATURE ON TUBING ADAPTER

Special Feature List (Unit 6)

UNIT 6: Non-standard tolerances may also be defined by the ordering code by using a "/" separator.

For example: 701S133A155/4/4/8 specifies $\pm 4^\circ\text{F}$ tolerance on UNIT 3 temperature, $\pm 4^\circ\text{F}$ tolerance on UNIT 5 temperature, and 8°F minimum differential

A Setpoint tolerances are min-max. differential shall be 8°F min	J Opening and closing setpoints are $\pm 5^\circ\text{F}$
B Opening setpoint is min or max.	K Closing setpoint is $\pm 2^\circ\text{F}$. Opening setpoint is min or max.
C Closing setpoint is min or max.	N Closing setpoint is $\pm 3^\circ\text{F}$. Opening setpoint given is min or max possible.
D Opening setpoint is $\pm 5^\circ$ with 8° to 18° differential. Closing setpoint given is min or max. possible	P Closing setpoint is $\pm 4^\circ\text{F}$. Opening setpoint given is min or max possible.
E Closing setpoint is $\pm 5^\circ$ with 8° to 18° differential. Opening setpoint given is min or max possible.	R Setpoint tolerances are Min-Max. Differential shall be 10°F Min.
F Closing setpoint is $\pm 4^\circ\text{F}$ with 11 to 19°F differential Opening setpoint is min or max possible.	S Opening and closing setpoints are $\pm 6^\circ\text{F}$. Differential shall be 10°F Min.
G Opening and closing setpoints are $\pm 3^\circ\text{F}$	U Setpoint tolerances are min-max. Specify minimum differential (example: U/8).
H Opening and closing setpoints are $\pm 4^\circ\text{F}$	V Opening setpoint is min or max. Specify closing tolerance and minimum differential (example: V/5/8).
	W Closing setpoint is min or max. Specify opening tolerance and minimum differential (example: W/5/8).

Tolerance Limits (Consult Factory for Non-standard Limits)

Specified Temp Setpoint Range	Standard Setpoint Tolerance
$^\circ\text{F}$ ($^\circ\text{C}$)	$^\circ\text{F}$ ($^\circ\text{C}$)
-120 to 0 (-84.4 to -17.8)	± 6 (3.3)
+1 to 250 (-17.2 to 121.1)	± 5 (2.8)
251 to 300 (121.7 to 148.9)	± 7 (3.9)

Configuration Drawings (dimensions in inches)

All configurations shown are available with upright terminals

<p>701</p>	<p>702</p> <table border="1"> <thead> <tr> <th>UNIT 7</th> <th>DIM "A"</th> </tr> </thead> <tbody> <tr><td>A</td><td>.500</td></tr> <tr><td>B</td><td>.438</td></tr> <tr><td>C</td><td>.375</td></tr> <tr><td>D</td><td>.312</td></tr> <tr><td>E</td><td>.250</td></tr> <tr><td>F</td><td>.187</td></tr> </tbody> </table>	UNIT 7	DIM "A"	A	.500	B	.438	C	.375	D	.312	E	.250	F	.187						
UNIT 7	DIM "A"																				
A	.500																				
B	.438																				
C	.375																				
D	.312																				
E	.250																				
F	.187																				
<p>703</p> <table border="1"> <thead> <tr> <th>UNIT 7</th> <th>DIM "A"</th> </tr> </thead> <tbody> <tr><td>A</td><td>.500</td></tr> <tr><td>B</td><td>.438</td></tr> <tr><td>C</td><td>.375</td></tr> <tr><td>D</td><td>.312</td></tr> <tr><td>E</td><td>.250</td></tr> <tr><td>F</td><td>.187</td></tr> </tbody> </table>	UNIT 7	DIM "A"	A	.500	B	.438	C	.375	D	.312	E	.250	F	.187	<p>704</p> <table border="1"> <thead> <tr> <th>UNIT 7</th> <th>DIM "A"</th> </tr> </thead> <tbody> <tr><td>A</td><td>.500</td></tr> <tr><td>B</td><td>.438</td></tr> </tbody> </table>	UNIT 7	DIM "A"	A	.500	B	.438
UNIT 7	DIM "A"																				
A	.500																				
B	.438																				
C	.375																				
D	.312																				
E	.250																				
F	.187																				
UNIT 7	DIM "A"																				
A	.500																				
B	.438																				
<p>705</p>	<p>706</p>																				

707 – REPLACED by 717

UNIT 7	TUBE DIA.	DIM. "A"
A	.250	.29
B	.375	.43
C	.373	.61

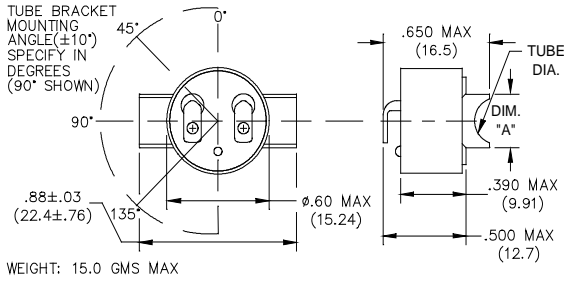

708

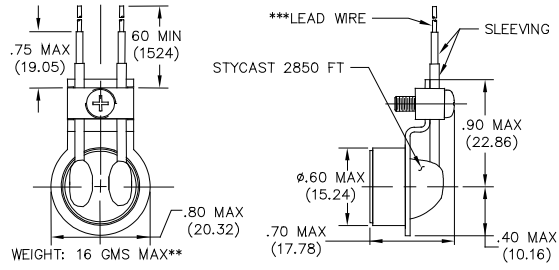

709

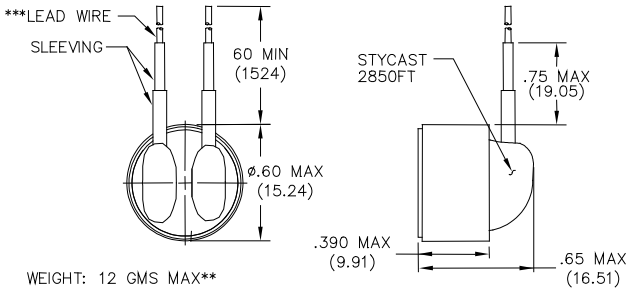

710 – REPLACED by 717

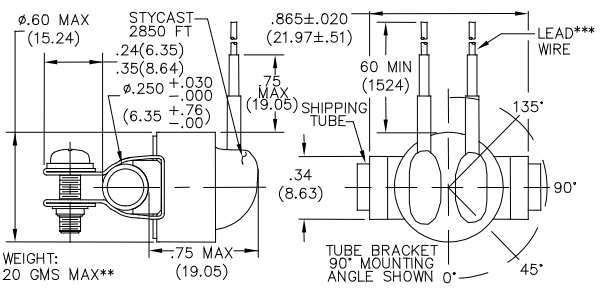

711

UNIT 7	DIM "A"
A	.500
B	.438
C	.375
D	.312
E	.250
F	.187

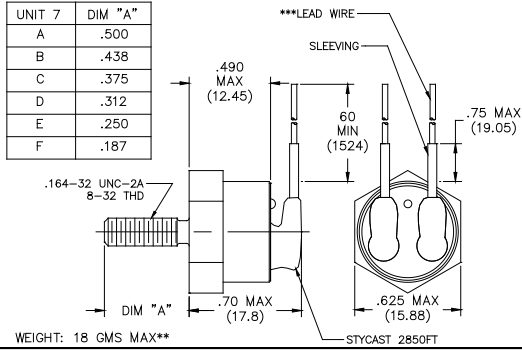

712

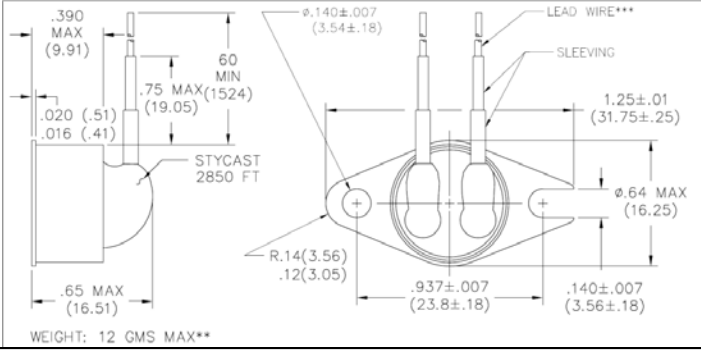

713 – REPLACED by 717

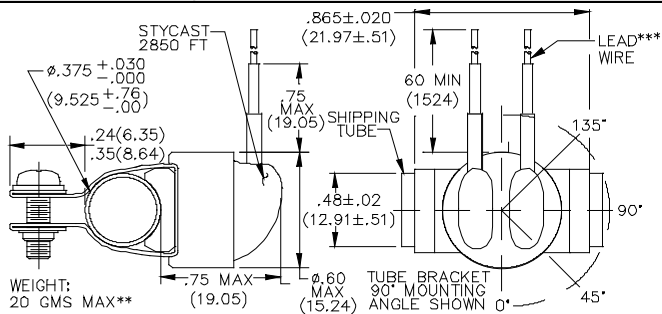

714 – REPLACED by 717

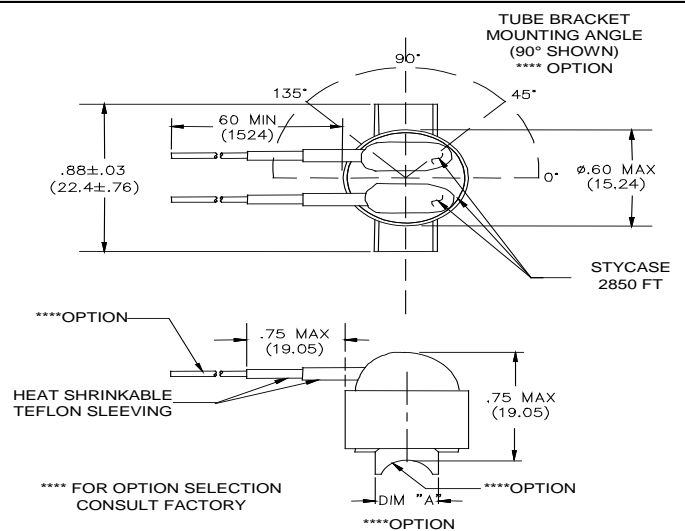

715 – REPLACED by 701, 705 & 706

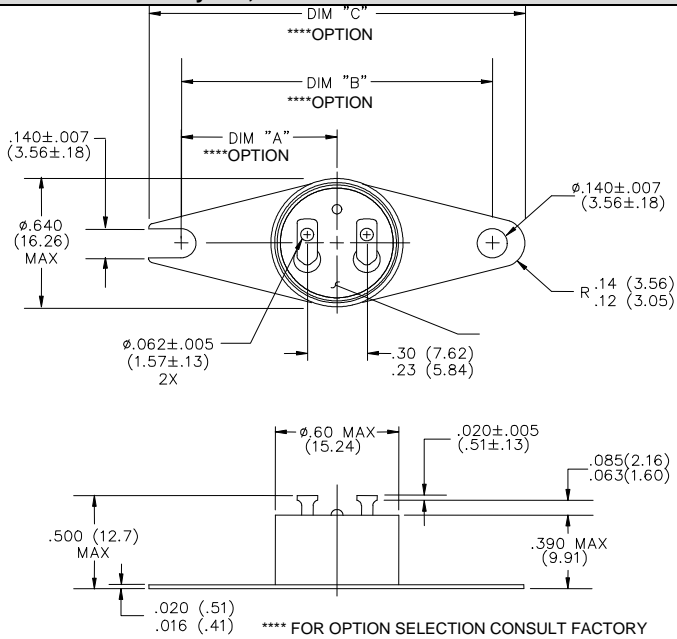

Typical Dimension for all configurations.
 ** "WEIGHT" does not include weight of lead wires.
 *** Wire (where applicable) MIL-W-22759/43

716 – REPLACED by 701, 705 & 706

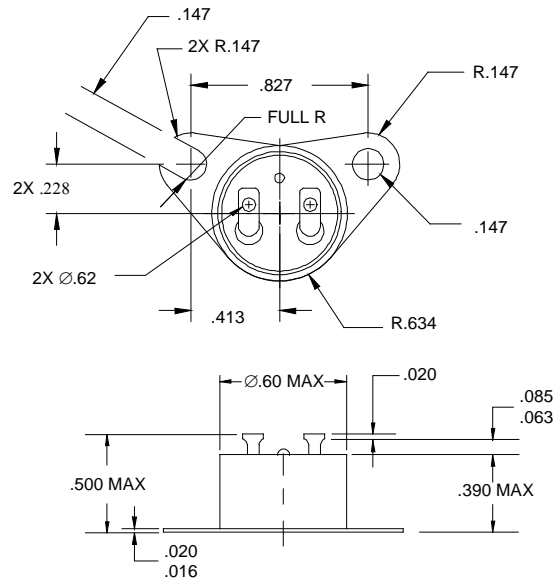

717 - Weights will vary with configuration.

1/4" diameter tube mount shown For other options, consult factory.

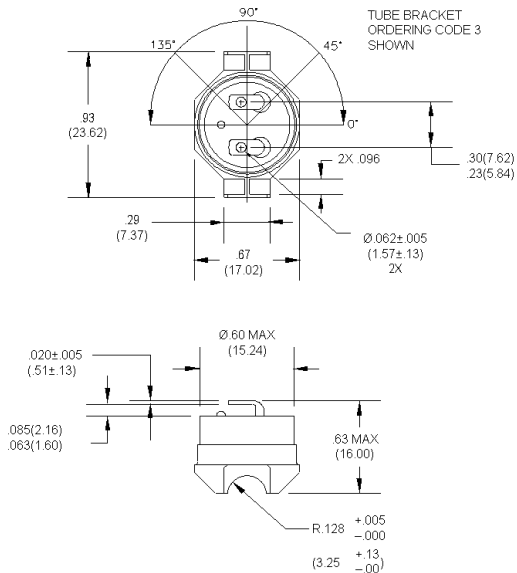

718 - Weights will vary with configuration.

1/4" diameter tube mount shown. For other options, consult factory.

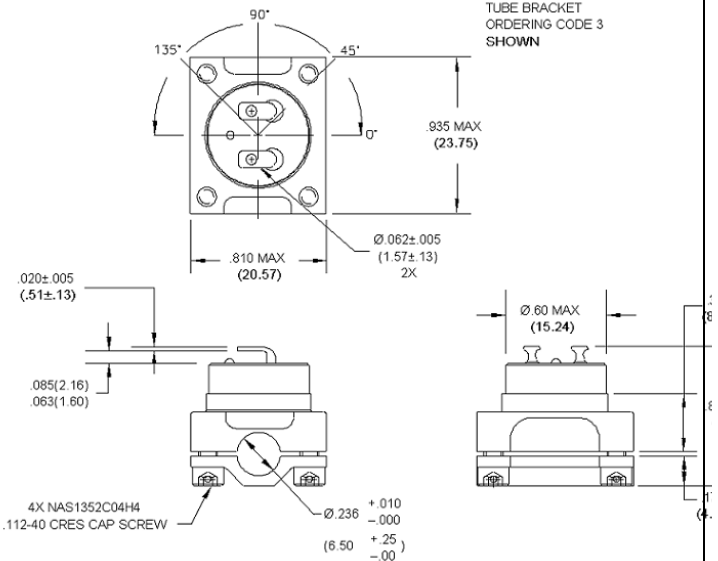

719

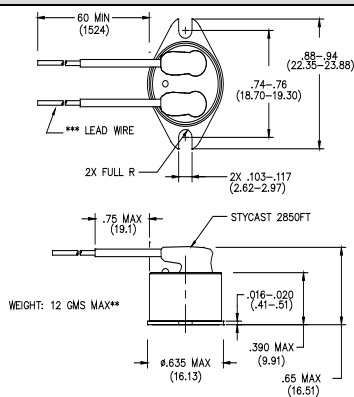

Find out more:
www.thermalswitch.com

Defense & Space Redmond

Honeywell International, Inc.
 MAIL ADDRESS: P.O. Box 97001
 15001 N.E. 36th Street
 Redmond, Washington 98073-9701
 PHONE: 425-885-8120

www.honeywell.com
ISO-9001 Certification Since 1995

DISCLAIMER: Specifications are subject to change without notice. Honeywell reserves the right to make changes to any product or technology herein to improve reliability, function, or design. Honeywell does not assume any liability arising out of the application or use of the product.

THERMAL SWITCHES exported from the United States must be done in accordance with the Export Administration Regulations (EAR) and/or the International Traffic in Arms Regulations (ITAR) as applicable.

TS700 EXP045 02/07
 Copyright © 2004, Honeywell International Inc. All Rights Reserved. Printed in USA

