

## TPE331-10 TURBOPROP ENGINE

Advanced engine performance and power generation capability

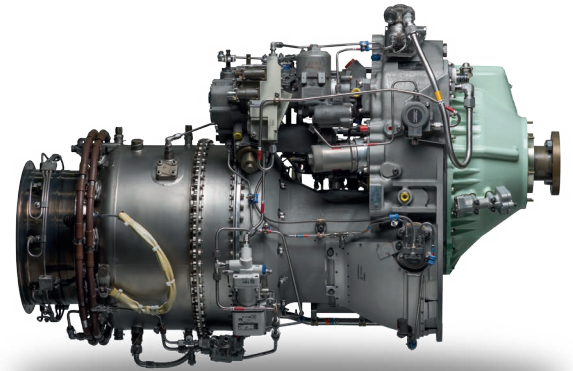

### Basic Engine Includes

- Control System
  - Single Red Line /Auto-Start Controller
  - Hydromechanical Fuel Control
- Propeller Governor
- Fuel Pump
- Fuel Shutoff Valve
- Fuel Anti-ice Heating System
- Dual Continuous Ignition System
- Lubrication System
- Propeller-Pitch Control
- Oil Temperature-Sensing Bulb
- Negative-Torque-Sensing (NTS) System
- Beta-Pressure Sensing Switch
- Fire-Shield Adapter
- Propeller Flange
- Torque and Temperature Limiting
- Fuel Purge System
- Air Speed and Ambient Pressure Ratio Transducer

### Optional Accessories/Features

- Water Methanol Augmentation Manifold
- Aluminum Gearbox

**High performance, increased performance and lower cost of ownership**

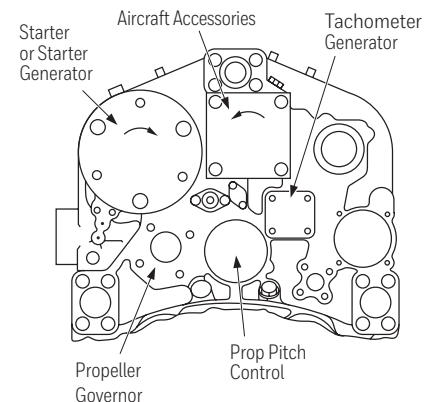
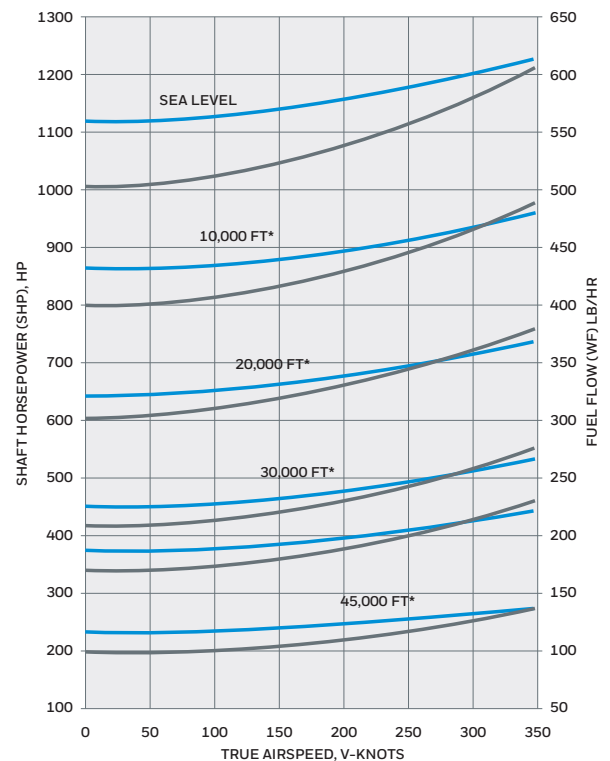

# TPE331-10 Turboprop Engine Specifications

(Sea level-standard day)

Power output:	shp shp (thermo) eshp eshp (thermo)	940 1,000 944 1,045
ESFC:	0.534	
RPM:	gas gen shatft output	41,730 2,000 (cw from rear) 1,591 (ccw from rear)
Weight:	385 lb	
Pressure ratio:	10.55	
Airflow:	7.7lb/sec	
Fuel:	Jet A, Jet B, Jet A-1, JP-8, JP-1, JP-4, JP-5, JP8+100	
Oil	Mil-L-23699B, Mil-L-7808, Type I/ Type II	
Electrical:	24 vdc, 16.2 amp (max)	
(Demonstrated) Start capability:	SL-30,000 ft. No minimum O.A.T. to +55°C	
(Demonstrated) Operational limits:	SL-45,000 ft. No minimum O.A.T. to +55°C	
Compressor bleed:	high pressure 10% (max)	

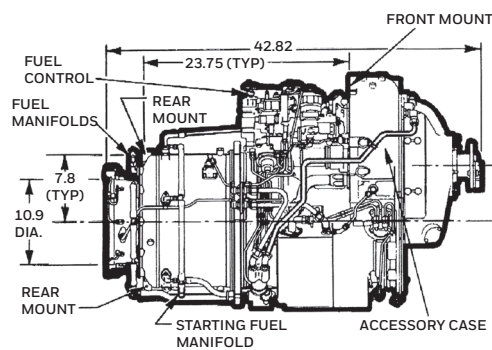
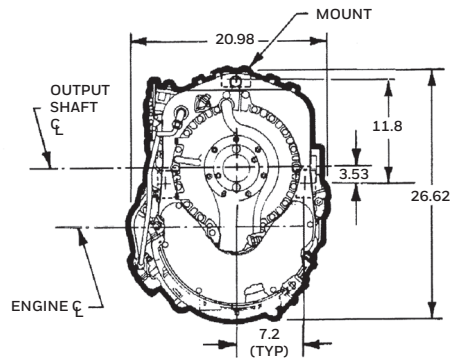

\*Available in cw and ccw

NOMINAL USE	TYPE OF DRIVE (ONE EACH)	AND DRIVE MODIFICATIONS	ROTATION FACING DRIVE PAD AND RPM	MAXIMUM TORQUE (lb-in)			OVERHUNG MOMENT (lb-in)
				CONTINUOUS	OVERLOAD	STATIC	
AIRCRAFT ACCESSORY	AND20001 TYPE X1-B (MODIFIED)	ROTATION AND RPM	CCW 3,959	250	375	1650	125
STARTER OR STARTER-GENERATOR OR ALTERNATOR	AND20002 TYPE X11-D (MODIFIED)	RPM, T <sub>c</sub> , T <sub>o</sub> , AND STUD PATTERN ROTATED 30 DEGREES	CCW 10,887	300	600	2200	500
TACHOMETER-GENERATOR	AND20005 TYPE XV-B (MODIFIED)	SHORTER STUDS AND THREAD LENGTHS	CW 4,187	7	-	50	25
PROPELLER GOVERNOR	AND20010 TYPE XX-A (MODIFIED)	Rpm, STUD LENGTH AND NEGATIVE TORQUE-SYSTEM SUPPLY PORT	CW 3,754	125	188	825	125

CCW=Counterclockwise    CW=Clockwise    T<sub>c</sub>=Continuous torque    T<sub>o</sub>=Torque Overload    T<sub>s</sub>=Static torque

**Honeywell Aerospace**  
1944 East Sky Harbor Circle  
Phoenix, AZ 85034  
aerospace.honeywell.com

N61-1491-000-000 | 08/16  
© 2016 Honeywell International Inc.

**Honeywell**