

APPLICATION NOTE

MOUNTING TIPS FOR LCC MAGNETIC SENSORS

ABSTRACT

Some of Honeywell's Anisotropic Magneto-Resistive (AMR) sensors are packaged in Leadless Chip Carrier (LCC) components for surface-mount attachment to Printed Circuit Boards (PCBs). This application note shall describe guidelines for approaching the correct methods for designing the mating circuit board pads for locating LCC components, and recommended process steps for successful solder reflow to bond the LCC to the PCB.

THE LCC ADVANTAGE

The rationale for the popularity of Leadless Chip Carrier packages comes from the size advantage and cost-effective materials used. When compared to packages with gull-wing leads, LCC packages offer significant reductions in PCB real estate needed for small, densely populated circuit boards. For instance the basic HMC1052 MSSOP lead package has about a 16mm² foot print (~4mm by 4mm) compared to the HMC1052L LCC package foot print of 9mm² (3mm by 3mm). The difference could mean the difference between design-in and not designing an electronic compass feature in small watches and hand-held wireless products.

Similar to low-cost leaded surface-mount packages, LCC packages use copper paddle/leadframes and epoxy over-mold processes. The assembly process is done in a reel-to-reel method starting with die placement/attachment, then following with ball bonding gold wires between the leads and die pads, epoxy molding, and stamping remaining leadframe supports from the completed package. All this assembly is done with a minimum of human intervention, and results in a high-volume, low cost packaging process. Figure 1 shows a typical cross-section of a LCC package.

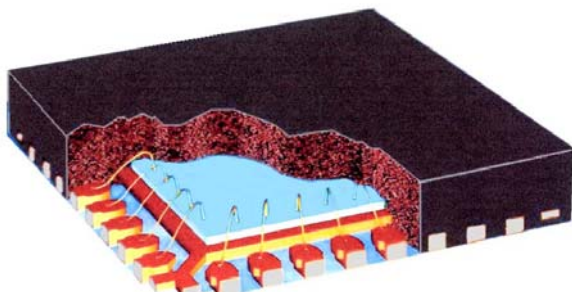

Figure 1
LCC Package Cutaway

LCC PACKAGE HANDLING

The epoxy encapsulated LCC packages for Honeywell's AMR sensors are non-hermetic and absorb moisture from the environment. When stored, it is recommended that standard "dry pack" procedures be implemented. These could be sealed bag storage with desiccant pouches and humidity indicator strips enclosed with the package. An alternative would be storage in a nitrogen dry box awaiting imminent transfer to the assembly line.

If several days of uncontrolled exposure of heat and humidity extremes (>30°C, >60%RH) are likely, a baking cycle prior to assembly should be initiated. This "bake-out" should be from 1 to 24 hours at +125°C, with 8-hours a recommended duration. With the LCC packages "dry" from a bake-out, little probability for excess internal vapor pressure and resultant "popcorning" at reflow will occur.

PCB DESIGN GUIDELINES

Mounting Honeywell magnetic sensors with LCC packages has a few extra guidelines beyond what normally applies to through-hole or standard SMT PCB rules for layout. The following paragraphs shall cover PCB solder "Land" pad sizing, thermal pad recommendations, solder mask usage, and magnetic material content issues.

LAND PAD SIZING

With the ever-shrinking package and pad sizes for LCC components, over-sizing the corresponding PCB land pads becomes an important consideration for reliable connections. This is even more so for some magnetic sensor applications as it is sometimes critical to locate the sensor with mechanical precision.

Figure 2 shows a typical bottom-side package layout for a LCC and also shows the pins and dimension conventions. Honeywell's LCC devices have exposed center pads, but do not have any electrical connection. It is recommended that the PCB not have a center pad feature and use the area for trace routing, and vias with cover-layer insulation to prevent shorting. Overall package dimensions "D" (side-to-side) and "E" (top-to-bottom) are not denoted in Figure 2, but the exposed pad contains the dimensions D2 and E2. Pad spacing or "pitch" is denoted by dimension "e" and maybe stated in English (mils) or Metric (milli-meters) values.

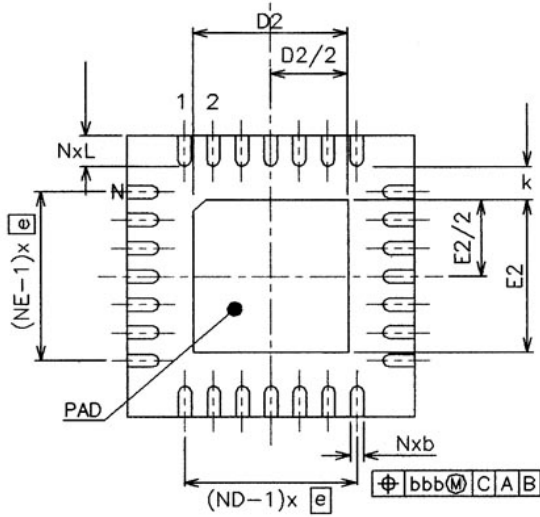

Figure 2
LCC Package Dimensions

The outside terminal pins are finger-shaped solder-coated with the outside edge flat and the inside rounded. The pin width is denoted as “b” and pin length is denoted as “L”. The clearance between the pin length and the exposed pad edges is “k”. Note that the terminal pins have no edge reference dimension and are based from the center of the package knowing the edge pin count, pin pitch, and pin width. Even pin edge counts will have a pin on the center line, and odd pin edge counts will have the center line between the pins (e/2).

Typical LCC “fine” pitch packages will nominally have 0.50mm pin pitch, with pin width in the 0.18mm to 0.30mm tolerance. Terminal pin lengths will nominally have 0.30mm to 0.50mm values. To design terminal pin lands, it is recommended that 0.025mm be added to each edge of the pin width pin land for a total width increase of 0.05mm. The inside land increase should be about 0.05mm, with the outside land increase about 0.20mm for both solder filleting and a location for probing the pins. Figure 3 shows the nominal land and pad orientation.

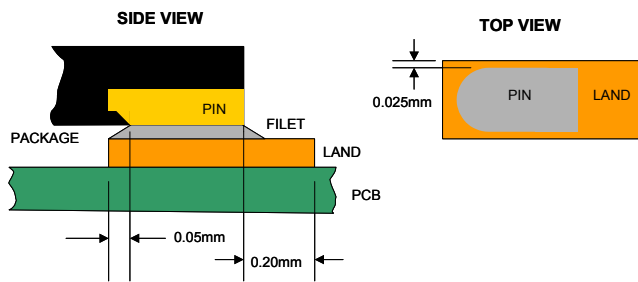

Figure 3
Land Pad Design

Putting all this together with the lands and pins, is shown in the example of Figure 4.

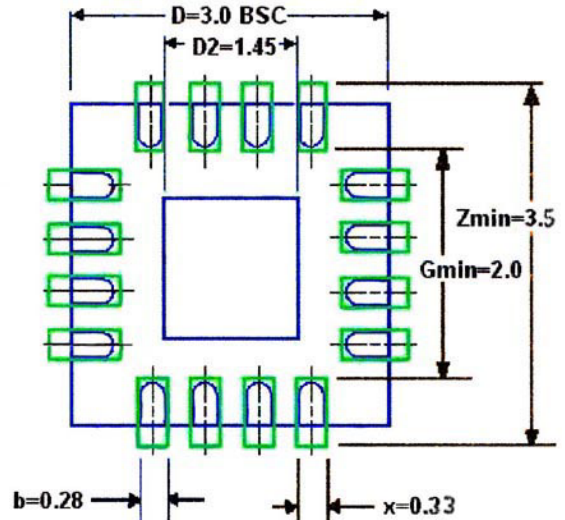

Figure 4
3x3mm LCC Example

Another important PCB layout item is that pin numbering proceeds clockwise from the bottom view of the LCC (counter-clockwise from the top). Either a chamfered corner of the center pad or a corner contact feature in lieu of the chamfer will always denote the pin 1 location. Figure 2 shows numbering method in the upper left side of the figure.

SOLDERING GUIDELINES

Most LCC packages have no special requirements beyond normal procedures for attaching SMT components to printed circuit boards. The exception to this process is Honeywell HMC products that have ceramic or FR4 substrate packages with epoxy top encapsulation. These package designs use two solder types with differing reflow temperatures. Inside these packages, a high-temp reflow solder is used that reflows at 225°C and above to make internal circuit connections. On the package outside, low-temp solder is recommended with a reflow temp range from 180 to 210°C.

Three heating zones are defined in SMT reflow soldering process; the preheating zone, the soaking zone, and the reflow zone. The preheating zone includes the soaking zone, and nominally ranges from 2 to 4 minutes depending on temperature rise to arrive in the 160°C to 180°C soaking plateau to activate the flux and remove any remaining moisture in the assembly. Preheat rise times must not exceed 3°C per second to avoid moisture and mechanical stresses that result in “popcorning” the package encapsulation.

The soaking zone is a one to two minute temperature stabilization time to bring the all the PCB assembly to an even temperature. Typically this zone has a 0.5 to 0.6°C rise in temperature heading towards the main reflow heating elements. The reflow zone is 30 to 90 second bump in temperature over the 180°C point to reflow the screened solder paste before a gradual cooling. The peak temperature is typically in the 210°C to 225°C range. In dual temp solder parts, it is recommended that peak temperatures remain at least 5°C below the internal reflow solder temperature (i.e. 220°C). Figure 5 shows a typical reflow profile.

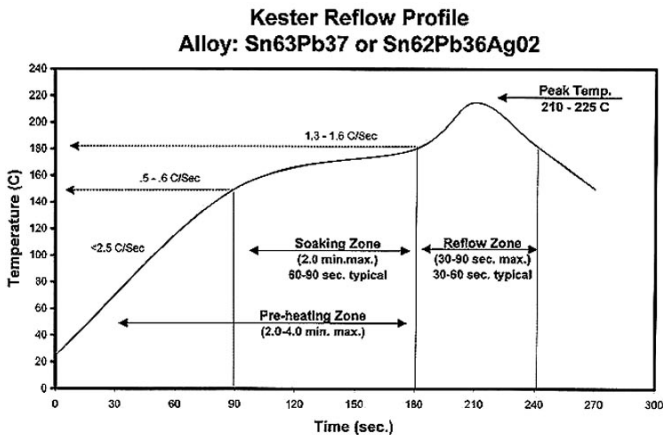

It should be noted that lead-free solders tend to require higher peak reflow temperatures and longer reflow times. Cooling zone temperature fall should decrease not more than 6°C per second to avoid mechanical stresses in the PCB assembly.

SUMMARY

The above tips for handling and attaching Leadless Chip Carrier packages should assure reliable operation of all electrical components used on printed circuit boards. For further questions, please call for applications support at 800-323-8295.

900310 7-04 Rev –