

### OVERVIEW

This application note describes the basic principles using magnetic sensors to measure current, offers several approaches to using MR technology, and lists the technical advantages and disadvantages to each approach. Since each application has its own unique set of specifications, the note serves as an overview to introduce the user to the basics of current sensing.

### INTRODUCTION

There are numerous methods used to measure current. The most common ways include the use of a resistive shunt, a transformer, or a magnetic sensor. Resistive shunts operate by Ohm's law giving a voltage proportional to the current going through the shunt. It is a resistor in series with the load. This offers good accuracy and low offset, but does not provide electrical isolation and has high thermal drift. This allows transient spikes to ruin the sensor and potentially overload the electronics. The current transformer is made up of a primary and a secondary coil wrapped around a magnetic core. The primary coil carries the current to be sensed and induces a magnetic field in the core. A current is generated in the secondary coil that is proportional to the primary current scaled by the turns ratio. The current transformer offers electrical isolation, but only works for AC applications. Current transformers can also be large and bulky.

Magnetic sensors may be used to take advantage of the strengths of both approaches. Honeywell's line of magnetoresistive sensors offer a high sensitivity, small size, solid state solution. Further, these devices may be used for non-contact current sensing, meaning they won't break the electrical circuit. This allows for electrical isolation and protection of the sensor and surrounding electronics. The use of the sensors' set/reset circuitry allows for ultra low offset and ultra low offset drift of current measurements. The MR sensors have a bandwidth of DC to 2 to 5 MHz, allowing for a wide range of current sensing applications. The sensors also have a wide dynamic range over 100 dB.

### CURRENT AND MAGNETIC FIELD

Current generates magnetic fields that can be measured using a magnetoresistive (MR) device. For instance, a round conductor carrying a current creates concentric rings of magnetic field lines about the conductor. The direction of the field induced is determined by applying the right hand rule: point the thumb of your right hand in the direction of the current flow and your fingers will curl in the direction of the magnetic field vectors as shown in Figure 1.

In most cases, magnetic field at a given point can be determined by applying the Biot-Savart Law or its simpler derivation, Ampere's circuital law. Ampere's law states that

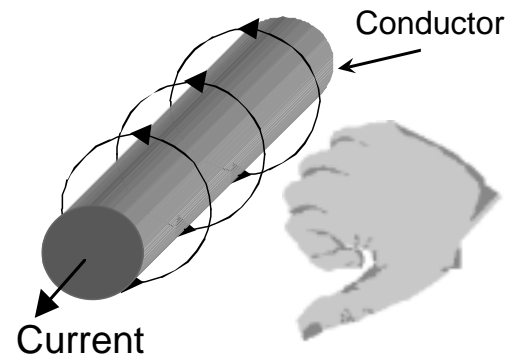

Figure 1.—Direction of magnetic field vs. current

the line integral of the magnetic field intensity ( $\mathbf{H}$ ) about any closed path is equal to the current enclosed within that path.<sup>1</sup> The equation is given below.

$$\oint \mathbf{H} \cdot d\mathbf{L} = I \quad (1)$$

Where  $\mathbf{H}$  is the magnetic field intensity,  $I$  is the current, and  $d\mathbf{L}$  is an infinitesimal section of the closed loop integrating path.

For a round conductor, if you integrate around a ring at a fixed distance  $r$ , the  $\mathbf{H}$  and  $d\mathbf{L}$  vectors always point the same direction. As shown in Figure 2,  $\mathbf{H}$  also has a constant magnitude since you are tracing one of the concentric circles. Since  $d\mathbf{L} = r d\theta$ ,  $\int \mathbf{H} \cdot \sum d\mathbf{L}$  becomes  $H \int r d\theta$  where  $\theta$  varies around the circle from zero to  $2\pi$  radians. The magnetic flux density ( $\mathbf{B}$ ) is  $\mu\mathbf{H}$  where  $\mu = \mu_r\mu_o$ .  $\mu_o$  is the permeability magnetic induction constant of free space ( $4\pi \cdot 10^{-7}$  H/m) and  $\mu_r$  is the relative permeability of the material. Air has a relative permeability of about one.

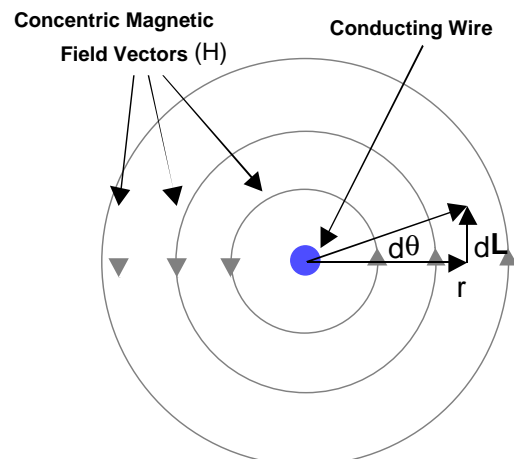

Figure 2.—Magnetic fields around a current carrying conductor

This gives you Equation 2.

$$\mathbf{B} = \frac{I\mu_o}{2\pi r} \mathbf{a}_t \quad (2)$$

Substitute  $\mu_o$  to get Equation 3 in SI units:

$$\mathbf{B} = \frac{2 * 10^{-7} I}{r} \mathbf{a}_t \quad (3)$$

When using SI units in the above equations, **B** comes out in Tesla. There are  $10^4$  gauss in a Tesla. For example, if  $I = 1$  amp and  $r = 1$  cm (0.01 m), then  $B$  is  $20\mu\text{T}$  or 0.20 gauss. Figure 3 shows the total field generated by an infinitely long wire carrying different currents. This shows, for example, that a wire carrying 1 amp produces a total magnetic field of 0.1 gauss at 2 cm from the conductor center. To the right of the chart is the measuring range of Honeywell's HMC series magnetoresistive sensors. Applications using these sensors in higher fields will be discussed in later sections.

Previously Ampere's Law calculation was integrated over a path of constant magnetic field intensity from an infinitely small wire. A change in geometry such as using a finite length wire, not having an exactly round current cross section, or having larger conductor will make it difficult to predict the constant field line distribution. A distribution for an infinite non-circular cross section is shown in Figure 4. The calculation approximated a wide conductor by placing 5 infinitely small wires each carrying two tenths the current spaced at 1.0 mm intervals. The calculation was made using a spreadsheet macro to calculate the total field induced by each  $1.0\text{mm}^2$  segment of the conductor. Each tic on the graph is a distance of 1.0 mm. Ampere's law assumes an infinitely small conductor. Because of this approximation, the simulation is not accurate for fields very

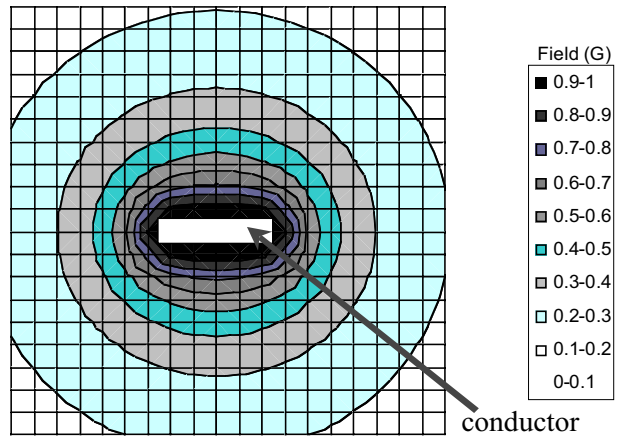

Figure 4—Infinite non-circular cross-section

close to the conductor. For this reason, Ampere's law is typically used for far field calculations. Note that the further the measurement is from the conductor, the more circular and predictable the distribution becomes. Then current can be treated as an infinitely small point. If you need to calculate very accurate fields for finite segments of current, near fields, or strange geometry, it is best to use some form of the Biot-Savart Law<sup>1</sup>:

$$\mathbf{H} = \oint \frac{I d\mathbf{L} \times \mathbf{a}_r}{4\pi R^2} = \int_S \frac{\mathbf{K} \times \mathbf{a}_r dS}{4\pi R^2} = \int_{vol} \frac{\mathbf{J} \times \mathbf{a}_r dv}{4\pi R^2} \quad (4)$$

where  $d\mathbf{L}$  is a small segment of current in an infinitely small wire,  $\mathbf{K}$  is surface current density (A/m), and  $\mathbf{J}$  is current density (A/m<sup>2</sup>).

## MR CURRENT SENSOR EXAMPLE APPROACHES

This section contains some sample current sensing approaches using Honeywell's magnetoresistive sensors. The data is estimated from calculations of fields generated by a wire. These predict the field to be sensed by the MR devices as point sensors. An initial step in the design process for any application is verification of these estimates empirically or with more advanced magnetic analysis.

## SENSOR ROTATIONAL ADJUSTMENT

Figure 3 shows that for large currents, the device must be relatively far from the wire to sense the full scale field produced by the current. The approach described here adjusts the field seen by the sensor by rotating the device within the magnetic field. The graph in Figure 3 gives the total field component at a given distance, however, magnetic field is a vector. The MR sensors measure field along a vector in the plane of the device. Therefore, the position of the plane may be rotated with respect to the field vector to measure a component of the total field. This allows the sensor to measure fairly large currents

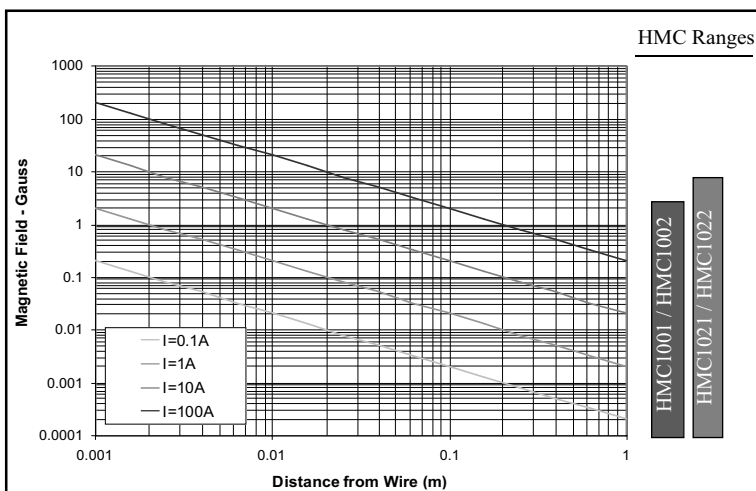

Figure 3—Total field with different currents

at distances closer to the device than if the total component was measured as in Figure 3. Figure 5 shows one way an MR sensor could be used in this approach. The resulting field that is measured ( $B_m$ ) is given below:

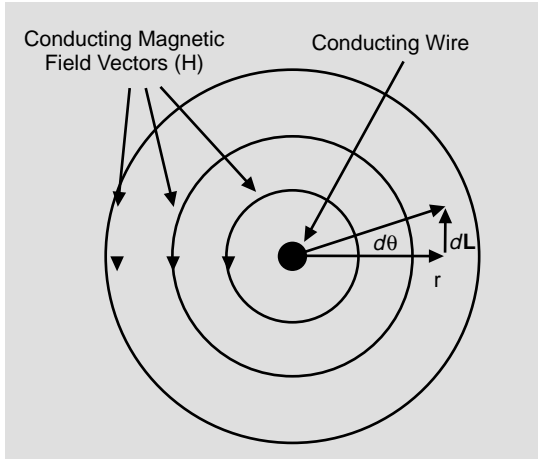

Figure 5—Sensing angle of a magnetic field

This assumes the field is fairly uniform over the sensing area of the device. Care must be taken to ensure that the unused field component is not coupled into the cross axis. Rotating the device about the cross axis can prevent cross axis errors. Further, the closer the angle  $\theta$  gets to  $90^\circ$ , the more sensitive the device is to the angle tolerance issues. For instance, if you place the sensor at a  $10^\circ$  tilt angle, the sensor will measure 98.4% of the total field magnitude. If there is a  $\pm 0.5^\circ$  mounting tolerance, the output will vary by 0.3% of this value. If instead the sensor is mounted at an  $80^\circ$  tilt angle, the sensor will measure 17% of the total field magnitude and have an error of 10% for a  $\pm 0.5^\circ$  mounting tolerance. This is shown in Figure 6. This approach can allow the device to measure large currents near the wire; however, it is limited by the tolerances of precisely placing a sensor at an angle to the field vectors.

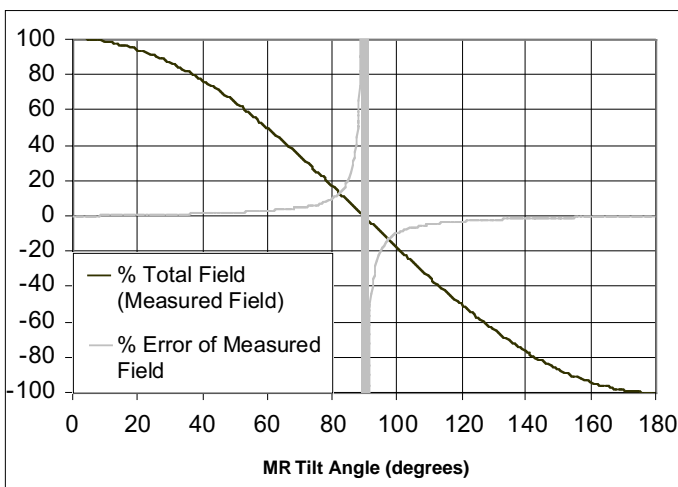

Figure 6—Full scale output vs sensor tilt

## WIRE POSITION ADJUSTMENT

A similar approach is to move the conductor with respect to the sensor. The sensor and wire may be placed as shown in Figure 7 so the sensor is at position  $(0,0)$  and the wire is at position  $(x_1, y_1)$ . Because the sensor measures just the y-component of magnetic field, Equation 3 should be broken up into just the y-component:

$$B_y = \frac{2 * 10^{-3} I}{R} \sin(\theta - 90) = \frac{-2 * 10^{-3} I x_1}{x_1^2 + y_1^2} \quad (5)$$

As seen by Equation 5, the measured component of field drops off inversely when the wire is moved in the x-direction and inversely squared when moved in the y-direction. The squared response allows the sensor to be placed relatively close to the device and only measure a small component of field.

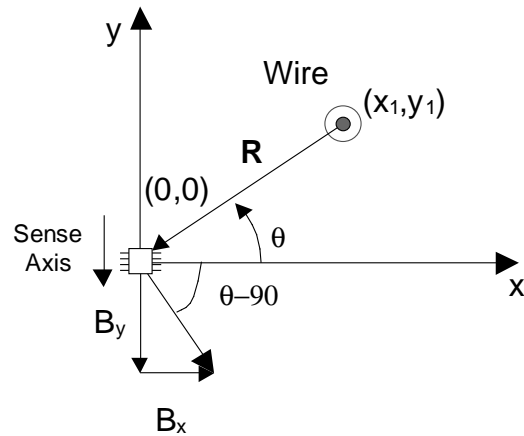

Figure 7—Sensing the position of a wire

Figure 8 shows the measured field component normalized to one amp for different  $x_1$  and  $y_1$  values. The values on the normalized graph may be adjusted to other currents by multiplying the value from the chart by the nominal current. For instance, if  $x_1 = 4$  mm and  $y_1 = 10$  mm, the field seen by the sensor from a 10 amp current would be 0.7 gauss ( $0.0x7 * 10$ ).

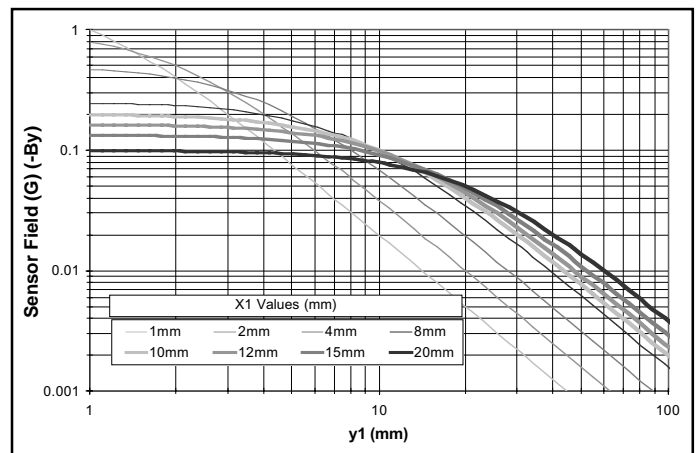

Figure 8—Measured field component for 1A current

As the wire moves closer to the sensor, the sensor should no longer be estimated as a point measurement. More advanced calculations are required. Also notice that for an infinite wire of this geometry, there is no induced cross axis field on the sensor.

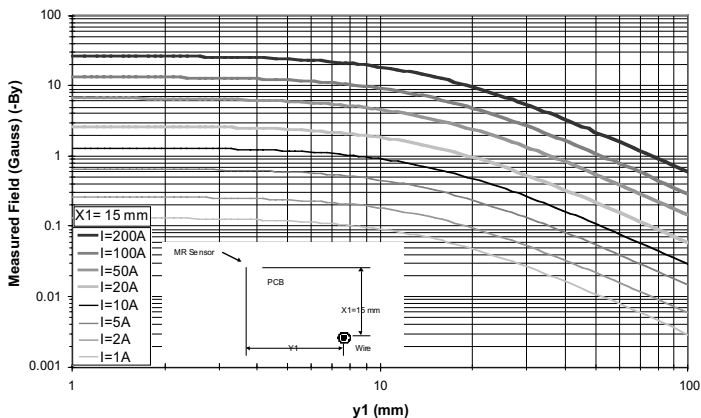

Figure 9—Measured field component for a displaced sensor

Figure 9 illustrates an example of how the sensor could be used in this configuration for  $x_1=15$  mm. The graph shows the field seen by the sensor for several different current levels. Figure 10 shows how this approach could be used in a device to measure between 10 and 500 amp full-scale values of current using the HMC1021Z. The device clips around wires carrying current. Use the smallest clip to measure  $\pm 10$  Amp signals or the largest clip to measure  $\pm 500$  Amp signals. If the full-scale current only represents the fault condition transients that must be measured, the application may allow smaller diameter wires. If the HMC1001 is used instead, the sensitivity is increased a factor of three. Therefore, the device could measure full-scale currents from 3.3 amps to 160 amps.

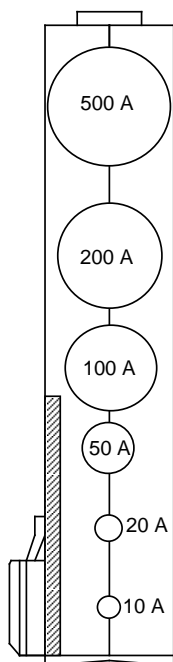

Figure 10—Values of current using HMC1021Z

The y-position is much more sensitive to exact positioning because of the squared nature of the field drop off. Table 1 estimates by calculation the precision of wire positioning that must be used to prevent  $\pm 5\%$  error in the signal. For  $x_1 = 3.5$  mm, it can be seen that the positioning needs to be quite precise:  $\pm 8$  mils variance in the y position gives  $\pm 5\%$  variation in the output for the 20 Amp position. Increasing the value of  $x_1$  can increase the allowable positioning tolerance. This is because the field is more uniform for larger  $x_1$  values. For example, the last row of Table 1 shows the tolerance for a 200 amp signal where  $x_1 = 15$  mm:  $\pm 35$  mils. The sensor does not measure field at a single point; the signal is integrated over the area of the die. This improves tolerance to position misalignment also.

A similar method could be used to measure currents in printed circuit board traces. The current trace could be run on one side of the board and the MR sensor would be placed on the second side. Because the sensor and the wire cannot be estimated as points, these suggested applications should be verified experimentally.

## USE OF LAMINATIONS AND CORES

Current sensing can also be designed to use a core or lamination to concentrate the flux. Figure 11 shows some typical approaches for using flux concentration in current sensing. The first figure is of a solid core current sensor; the second figure is of a lamination stack. Laminations are used since thinner material can carry higher frequency magnetic flux. The laminations and cores are made of a highly permeable material that traps magnetic flux. Iron tends to have a relative permeability of about 2000 with respect to air. This means iron is 2000 times more capable to carry magnetic fields and therefore fields are concentrated in the material. Typical core materials can have permeability from 2000 to over 100,000. A magnetic sensor is placed in the gap of the core or lamination and the current carrying wire is placed through the hole. The magnetic field from the current is trapped in the core and crosses the sensor at the gap.

FS Current (Amp)	X1 (mm)	Y1 (mm)	FS Transfer Function (G/A)	Y Tolerance for $\pm 5\%$ FS Error	
				(mm)	(mils)
10	3.5	0	0.57	$\pm 0.2$	$\pm 8$
20	3.5	3.3	0.4	$\pm 0.2$	$\pm 8$
50	3.5	6.8	0.3	$\pm 0.2$	$\pm 9$
100	3.5	10.2	0.12	$\pm 0.3$	$\pm 11$
200	3.5	14.9	0.06	$\pm 0.4$	$\pm 17$
500	3.5	21.3	0.015	$\pm 0.5$	$\pm 21$
200	15	27.9	0.06	$\pm 0.9$	$\pm 35$

Table 1: Wire position tolerance along y direction for  $x_1=3.5$  mm.

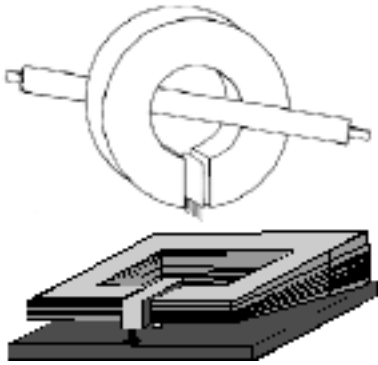

Figure 11—Use of lamination or core

The core also works well to shield the sensor from external magnetic fields (i.e. earth's field or stray fields from other currents), because external field lines would rather remain in the core by going around the back of the lamination than jump the gap through the sensor. The gap has a much higher magnetic reluctance. A magnetic model of stray magnetic field in a lamination is shown in Figure 12.

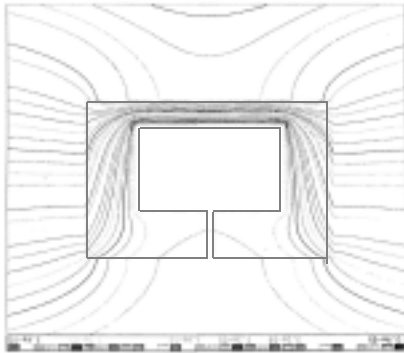

Figure 12—Stray magnetic field

The lamination can be seen as a rectangular doughnut with a small gap for the sensor. The horizontal lines are from the stray magnetic field. Most of the external field avoids the gap where the sensor is placed and is concentrated on the backside of the lamination. A two-dimensional FEM analysis (shown in Figure 13) indicates how the shielding from external fields is increased as a function of the material permeability and the size of the lamination gap. As ex-

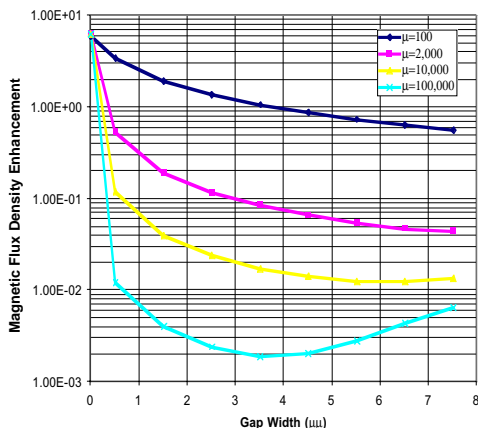

Figure 13—Two dimensional model of lamination shielding gap from stray magnetic fields.

pected, it is predicted that a larger gap decreases the amount of stray field in the gap. The use of cores is an excellent way to shield sensors from external fields, however, this increases size and complexity of assembly.

Positioning requirements of the wire are greatly relaxed when using a core or lamination. The wire can often move many times its diameter without even moderately affecting the accuracy of the sensor. This is because of how well the core will direct flux across the gap. The wire may also be wrapped through the core several times to amplify the flux in the core. With five turns, 10 amps will drive a 50 amp sensor full scale.

Cores and laminations work well for measuring differential current between two lines. This is because the flux from each wire will be almost completely trapped in the highly permeable material. The flux from each wire then cancel to leave just the difference in current. This is a good way to measure differential currents with high common mode rejection, loose wire position tolerances, or both.

There are some issues to consider when using a core or lamination. The materials may display hysteresis and be magnetized in one direction even if there is no field generated by the current. This shows up as a variable offset and can cause heating in the device. Also, if the magnetic field is too large in the lamination, the material can become saturated. This means that the magnetic reluctance increases to the point that its permeability becomes the same as air and flux is no longer trapped.

## CLOSED LOOP CURRENT SENSING

The sensors may be operated in closed loop modes, extending their current measuring ranges further. In closed loop, the sensor is placed in a compensating field which drives the field across the sensor to zero. The compensating field is generated by a coil with a set turns ratio. Therefore, the current in the feedback coil is proportional to field applied from the primary current scaled by the turns ratio. Typically, a load resistor is placed in series with the coil to measure a voltage proportional to the input current. An example of how this could be done is shown in Figure 14.

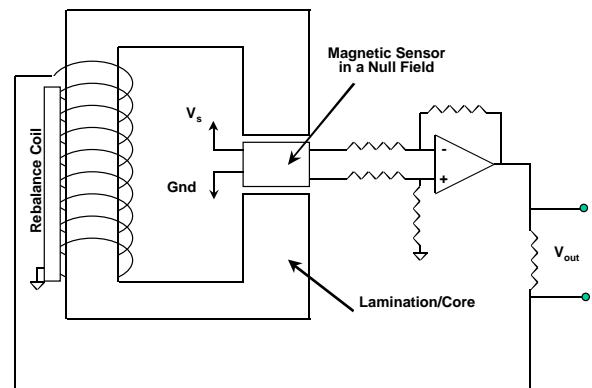

Figure 14—Measuring current in a closed loop

There are several advantages to operating in closed loop.

- It allows for larger current ranges without saturating the sensor.
- The output is highly linear.
- Closed loop allows for higher accuracy.
- Closed loop systems generally have higher bandwidths.
- High loop gain in the feedback loop makes the performance insensitive to component variations.
- The dynamic range of the device is much larger.

In general, closed loop current sensing is an accurate and effective way to measure current.

## SOLUTIONS TO CURRENT SENSING ISSUES

There are some issues that are common to many of the different current sensing approaches listed above that will be discussed in this section. They include methods of dealing with stray fields and methods to reduce the offset of a current sensor and its offset drift with temperature.

### DEALING WITH STRAY FIELDS

Uncontrolled stray magnetic fields can severely degrade the performance of a current sensor. For instance, earth's magnetic field is about one-half gauss. This is 4% of the full swing of the HMC1021 and 12.5% of the linear swing of the HMC1001. It is important in current sensor design to identify if the effect of stray fields will prevent your device from operating properly. Is the desired resolution of the current sensor less than what can be achieved without removing the stray field effects? If so, there are several methods for dealing with stray fields.

One of the easiest ways to remove the effects of an unwanted magnetic field is to remove the signal electrically with a filter. AC coupling can be used to remove the effects of DC fields such as earth's field or a nearby DC current. Low pass filtering can be used to remove unwanted high frequency components or 50/60 Hz fields. It is important to be sure that the sum of the stray fields and the fields to be sensed are not driving the sensor out of its linear range. This would degrade the performance of the current sensor. The filtering approach is not as useful for large stray fields that saturate the sensors or stray fields at frequencies where measurements are to be made. High frequency fields can be removed by using a choke or shading ring around the laminations. Fast changing magnetic flux through the ring induces eddy currents in the ring to oppose this change in flux. This provides a magnetic low pass filter.

A second approach is to shield the current sensor from stray magnetic fields. This can be done by enclosing the sensor in a material with high permeability. This material should be thick enough not to saturate in the presence of the stray field. Care must be taken in this approach since the magnetic field lines from the current may be in the shielding material rather than near the sensor. Then the sensor has been shielded from all fields including the one to be measured.

Improper design of a magnetic shield can also lead to flux concentration where shielding was desired.

A better way to shield is to make use of a lamination or core. These actually perform two functions: strong shielding from stray fields and position tolerant concentration of current induced flux. This is one of the most effective ways to shield against external fields in current sensing. However, laminations are larger and more expensive than a "No-lam" stray field tolerant approach.

Another approach is to use two sensors so the stray field becomes a common mode signal that may be removed from the differential signal. Figure 15 demonstrates how this may be designed. In one sensor the stray field and the sensed field are summed; in the second sensor they are subtracted. This works for stray fields that are uniform over the volume of the two sensors. As with filtering techniques, the stray fields still affect the sensors. The size of these fields must not drive the sensor beyond the linear range when summed with the field to be sensed. The performance of such an approach is very dependent on the symmetry of the stray fields and the symmetry of the position between the two sensors.

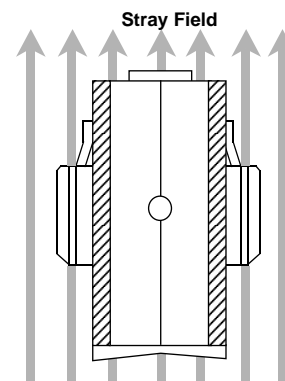

Figure 15—Using 2 MR sensors to remove the effects of a uniform stray field

Sometimes methods to reject stray fields can be designed specifically for an application. For some applications, the field to be sensed is known. This may be at startup, in sleep mode, or at periodic no load levels. In these cases, the output can be sampled and the difference from the known value is subtracted from the signal. This may be an appropriate approach to remove DC stray fields and offsets.

### DEALING WITH SENSOR OFFSET

In current sensing, sensor offset and offset drift with temperature can be important parameters in a design. MR sensors consist of four magnetoresistors placed in a wheatstone bridge configuration. An offset results when the ratios of the resistors in each branch of the bridge are not matched. This results in there being a small signal on the differential output when there is no magnetic

---

field present. This offset drifts when the resistance of at least one leg of the bridge changes at a different rate over temperature than the others. It is important in current sensor design to identify if the effect of magnetic sensor offsets will prevent your device from operating properly. Is the desired resolution of the current sensor less than what can be achieved without removing the offsets? If so, there are several methods for dealing with sensor offset and offset drift with temperature.

The most powerful method for removing offset from a sensor is through the set/reset operation. This is one of the big advantages of using MR technology over other magnetic approaches. The set and reset states create output voltages in opposite directions across the MR sensor. The magnetic domains of the magnetoresistors are aligned one way in the set state and the opposite direction from the reset. During a set and reset, the offsets of the resistors remain the same, but the output magnetic signal changes polarity. The two output values can be subtracted to remove the offset from the output. Using the set/reset approach, Honeywell's HMC1001 and HMC1021 have an offset drift of only  $\pm 10$  ppm/ $^{\circ}\text{C}$ . This ultra low offset is much better than is found in competing technologies. Other MR vendors require external coils to perform set /reset operations, but Honeywell has patented on-chip straps. This dramatically reduces power, size, and cost. Refer to SSEC's application note *AN-201: SET/RESET PULSE CIRCUITS FOR MAGNETIC SENSORS* for more information.

## CONCLUSION

There are several methods to measure current, but magnetoresistive (MR) sensors have distinct advantages over competing technologies. Honeywell is well positioned as the world leader in MR technology. Magnetoresistive current sensors can be small, low power, surface mount, isolated, non-contact, ultra-low offset, high sensitivity, large dynamic range, and wide bandwidth devices. They can be used in open loop or closed loop approaches and may be used from DC up to 5 MHz. These distinct advantages make MR sensors the best choice for most current sensor designs.

<sup>1</sup> Hayt, W. H., *Engineering Electromagnetics* (McGraw-Hill Book Company, New York, 1989) p. 224.

<sup>2</sup> Hayt, W. H., *ibid*, pp. 217–220.

Customer Service Representative  
1-800-323-8295 fax: (763) 954-2257  
E-Mail: [ssec.customer.service@honeywell.com](mailto:ssec.customer.service@honeywell.com)

Honeywell reserves the right to make changes to any products or technology herein to improve reliability, function or design. Honeywell does not assume any liability arising out of the application or use of any product or circuit described herein; neither does it convey any license under its patent rights nor the rights of others.

**Honeywell**